



**CENTA GROUP**  
COMPLETE FIRE PROTECTION

### INSPECTION & MAINTENANCE:

It is a requirement of the OSH Act that all fire extinguishers be maintained in accordance with the manufacturers specifications and **SANS 1475**.

INSPECTION is a quick test to ascertain that the extinguisher is working. Check the discharge hose to ensure the unit has not been discharged, that there is no obstruction of the discharge device and the gauge is showing pressure. Using a pressure testing tester, ensure the pressure in the cylinder is as per the stated specifications. MAINTENANCE of **CENTA** fire extinguishers must be carried out in accordance with the procedures as laid out in **SANS 1475**.

### SERVICING PROCEDURE:

Servicing **CENTA** products may only be undertaken by registered **SAQCC-Fire 1475** competent persons, who are employed by a **SANS 1475** approved company. Servicing and servicing intervals must comply with **SANS 1475**.

### SERVICING TIPS:

1. When commencing servicing ensure the unit is not under pressure, regardless of the gauge reading. Partially release the pressure relief valve. If a hissing sound is heard release pressure before working on the unit.
2. It is dangerous to 'break/unscrew' the valve, as a valve thread release may not be present.
3. When filling a foam extinguisher premix the foam and water before gently pouring into the unit.
4. Using a light film of grease on the cylinder neck and valve neck 'O' ring prevents leakage and preserves the 'O' ring.
5. When refitting a valve to a cylinder always replace the valve neck 'O' ring and ensure aluminum valve threads are greased.
6. Use a light solvent to clean all parts of the valve. Do not grease valve stem 'O' ring.

### WARNING:

Only pressurized stored pressure extinguishers with dry nitrogen from a cylinder with a regulator set at no greater than 1500kpa. Never pressure without a regulator.

### TOOL REQUIREMENTS:

The following tools will assist in the productive servicing of **CENTA** fire extinguishers:

- CENTA valve spanner
- No 10 spanner removes pressure relief nut
- No 14 spanner removes nozzle
- No 22 spanner removes gauge
- Light hammer removes valve handle pin



# FIRE EXTINGUISHER

1.0 KG Stainless Steel (Al2110)



### SPECIFICATIONS:

Height (mm):	355
Diameter (mm):	88.9
Mass Empty (kg):	0.92
Mass Full (kg):	1.92
Medium:	MAP Powder
Charge:	Dry Nitrogen
Discharge distance (m):	8
Working pressure (kPa):	1500
Filling Ratio:	-
Paint coating:	Polished
Compliance:	SANS 1910

### CENTA HEAD OFFICE:

Unit 5, 3 Sasswood Road, Glen Anil, Durban North, SA  
CALL: 0860 10 20 41 EMAIL: [centa@centa.co.za](mailto:centa@centa.co.za)

[WWW.CENTA.CO.ZA](http://WWW.CENTA.CO.ZA)

# EXPLODED VIEW

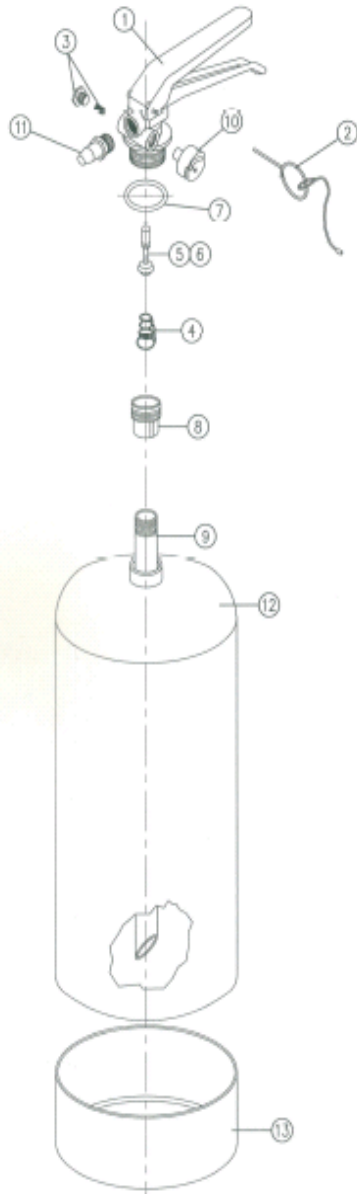

1	A08021	Small handle valve
2	AS2100	Safety pin
3	AS1800	Pressure relief spring & cap
4	AS2400	Plunger Spring
5	AS1700	Plunger & O-Ring
7	-	Valve seat O-ring
8	AS2300	Syphon tube holder
9	A08108	Syphon tube (195mm)
10	A07999	Standard pressure gauge
10	A08000	<b>Optional:</b> Ebur Gauge
11	A10214	Nozzle –Hose Connector
12	-	Cylinder
13	-	Steel foot

## TROUBLESHOOTING GUIDE

### **WARNING:**

Repairs must never be conducted on an extinguisher, until the internal pressure has been released. It is advisable to determine leaks before releasing the pressure.

PROBLEM	CORRECTIVE ACTION
<b>UNIT LOSING PRESSURE</b>	CHECK: <ul style="list-style-type: none"> <li>•Cylinder for pin hole leak</li> <li>•Valve for leak</li> <li>•Neck 'O' ring joint for leak</li> </ul>
<b>VALVE LEAK</b>	CHECK VALVE STEM: <ul style="list-style-type: none"> <li>•'O' ring is clean and has not been cut.</li> <li>•Chamber is clean.</li> </ul>
<b>GAUGE THREAD LEAK</b>	Remove gauge, and reinstall using loctite or thread tape on the gauge thread. Clean 'O' ring on valve.
<b>NECK 'O' RING LEAK</b>	Remove valve. Ensure neck ring area is free of dirt. Remove excess paint. Replace valve neck 'O' ring. Grease the neck and neck 'O' ring. Replace the valve.
<b>DEFECTIVE GAUGE</b>	Excessive shock can damage gauges. If damaged, remove gauge and replace.
<b>CYLINDER LEAK</b>	CENTA units carry a conditional warranty. If the unit is under three years old and in good condition the cylinder will be replaced.

## EXTINGUISHER MAINTENANCE INTERVALS

TYPE	CONTAINER MATERIAL	STORED PRESSURE OPERATION	MAINTENANCE INTERVALS	
			MAINTENANCE (years)	INTERNAL INSPECTION & PRESSURE TEST (years)
Dry powder	MS	SP	1	5
	SS	SP	1	5
Water	MS	SP	1	5
	SS	SP	1	5
Foam	MS	SP	1	5
	SS	SP	1	5
CO2	AL	SP	1	10 *
	CrMo	SP	1	10 *

### \* PRESSURE TEST INTERVALS FOR CO2 EXTINGUISHERS

All CO2 Fire Extinguishers manufactured **prior to the year 2000** shall be pressure tested at **5 year intervals**, until they have been tested by an approved test station (refer to **SANS 10019**), thereafter the intervals will be **10 years**.